

Vedic Mathematics, Science & Technology course

PART – XIII **ORGANIZATION OF VEDAS** (Chase steps 79, 80, 81, 82, 83, & 84)

Chase Step – 79
VEDAS

Chase Step – 80
UPVEDAS

Chase Step – 81
RIGVED

Chase Step – 82
YAJURVED

Chase Step – 83
SAMVED

Chase Step – 84
ATHARAVVED

I INTRODUCTORY

1. Vedas are the prime source of virtues, values orders and features of the Discipline of VMS & T.
2. Vedas are the transcendental reservoir of pure knowledge as well as of applied values of knowledge.
3. Organization of Vedic knowledge as well as is the knowledge stand simultaneously organized and as such the organization of knowledge is to be followed to reached at pure and applied values of knowledge preserved as Vedas.

*

Chase Step – 79
VEDAS

4. Originally the whole range of knowledge was constituting single wholesome VED.
5. Braham Rishi Ved Vyas re-organized wholesome Ved as four Vedas : Rigved, Yajurved, Samved and Atharaved.
6. Rigved accepts 21 branches, Yajurved accepts 101 branches, Samved accepts 1000 branches and Atharav accepts 9 branches.
7. Each of the Vedic branch has its distinct Samhita, Brahman, Aryanik and Upnishad. This way there are $1131 \times 4 = 4524$ scriptures together constituting Vedas.
8. Each Ved has distinct Upved. Upved as well being of the order of Ved as such Upved are also designated and accepted as Vedas.
9. Upved of Rigved is Ayurveda. Upved of Yajurved is Dhanurveda. Upved of Samved is Ghandaraved and upved of Athravved is Sathapatya ved.
10. Formulation Rik 'ऋक्' accepts simple English rendering as line / linear sequencing.
11. Formulation 'यजु' accepts simple English rendering as rope / thread.
12. Formulation 'साम' accepts simple English rendering as 'essence'.
13. Formulation 'अथर्व' accepts simple English rendering as 'stable flow'

14. Formulation 'वेद' is of transcendental code value '20' = TVC (वेद) and further as TVC (वेदः) = 33.
15. Synthesise value of quadruple dimensions of every order as well as is $20 = n + (n+2) + 6 (12-2n)$.
16. For proper chase of Vedas for reaching at virtues, values, order, features of the conceptual base of Discipline of VMS & T, as a first step, need would be to compile the transcendental code values of different formulations of Vedas beginning with single letter and single syllables and chase to cover the whole range of Vedic formulations.
17. It is going to be a big exercise. However every step towards it would be a reward in itself
18. Illustrative beginning towards it may be as follows:

Sr	TCV value	Formulation	TVC chase
1	1	क, अ, य -	Single letters tvc value 1
2	2	ख्, च्, इ, श्, ळ	Single letters tvc value 1
3	3	ग, छ, उ, स्, र्, ट्	Single letters tvc value 1
4	4	घ, ज्, ट्, ऋ, त्	Single letters tvc value 1
5	5	ड्, झ, ड्, लृ, प्, ल्	Single letters tvc value 1
6	6	, ढ्, ढ्, फ्, ष् ए	Single letters tvc value 1
7	7	ओ, ण्, घ्, ब्, व्	Single letters tvc value 1
8	8	न्, भ्, ऐ	Single letters tvc value 1
9	9	, म्, ह्, औ	Single letters tvc value 1
10	10	ॐ	Single letters tvc value 1
11	11	ॐ	Single letters tvc value 1
12	12	ॐ	Single letters tvc value 1

13	13	:	Single letters tvv value 1
14	14	५	Single letters tvv value 1
15	15	()	Single letters tvv value 1
16	16	ॐ	Single letters tvv value 1

19. Illustrative beginning of two letters formulations, with one consonant say (क्) and a vowel may be as follows

Sr	TVC value	Formulation	Formulation chare
1	1+ 1 = 2	क् + अ = क	Two letters formulation
2	1+ 2 = 3	क् + इ = कि	Two letters formulation
3	1+ 3 = 4	क् + उ = कु	Two letters formulation
4	1+ 4 = 5	क् + ऋ = कॠ	Two letters formulation
5	1+ 5 = 6	क् + ॠ = कॠ	Two letters formulation
6	1+ 6 = 7	क् + ए = कए	Two letters formulation
7	1+ 7 = 8	क् + ओ = को	Two letters formulation
8	1+ 8 = 9	क् + ऐ = के	Two letters formulation
9	1+ 9 = 10	क् + औ = कौ	Two letters formulation

20. Parallel to transcendental code values compilations, there also would be need for tabulation of artifices values in terms of sole syllable Om (ॐ), which is having transcendental code value 16 = 10 + 6 parallel to TVC value 10 for anusawar and TVC value 6 for औ . The artifices pair (10, 6) permit re-organization as 10 = 1 + 2 + 3 + 4 and 6 = 0 + 1 + 2 + 3, which infact are parallel to quadruples of manifestation folds of respective manifestation layers. Here further it would be relevant to note that these values accepts expressions along 4 x 4 format with summation value 16 as under :

Summation value	-2	-1	0	1 = -2
	-1	0	1	2 = 2

$$\begin{array}{cccc}
0 & 1 & 2 & 3 = 6 \\
1 & 2 & 3 & 4 = 10 \\
\text{Total summation value} & = & 16 &
\end{array}$$

21. Here it would be relevant to note that north east diagonal is affine diagonal of equal values as 1 at its all the four stages. This feature of summation value along diagonal as $1 + 1 + 1 + 1 = 4 = 4 \times 1$ and the summation value of the 4×4 matrix being $16 = 4 \times 4$, will help us appreciate that summation values comes to be $16 \times 1 =$ value of sole syllable Om (ॐ) i.e. $16 = 1$.

22. This will help comprehend as to how along 4×4 matrix, affine diagonals of values 1, 2, 3, 4, ---- can be reached at with total summation values of such matrices being $16 + 1, 16 \times 2, 16 \times 3, \text{-----}$.

$$\begin{array}{cccc}
\text{Summation value} & -1 & 0 & 1 & 2 = 2 \\
& 0 & 1 & 2 & 3 = 6 \\
& 1 & 2 & 3 & 4 = 10 \\
& 2 & 3 & 4 & 5 = 14 \\
\text{Total summation value} & = & 32 &
\end{array}$$

$$\begin{array}{cccc}
\text{Summation value} & 0 & 1 & 2 & 3 = 6 \\
& 1 & 2 & 3 & 4 = 10 \\
& 2 & 3 & 4 & 5 = 14 \\
& 3 & 4 & 5 & 6 = 18 \\
\text{Total summation value} & = & 48 &
\end{array}$$

23. Further a chase along $1 \times 1, 2 \times 2, 3 \times 3, 4 \times 4, 5 \times 5, 6 \times 6, 7 \times 7, 8 \times 8, 9 \times 9, 10 \times 10$ will help us have an insight about different values format availed by Vedic systems for the chase of value of '1' as affine diagonal of different lengths :

$$\begin{array}{lcl}
1 \times 1 & = & 1 \quad 1^2 = \sqrt{1} \\
2 \times 2 & \begin{array}{l} 0 \ 1 \\ 1 \ 0 \end{array} & = 2 = \sqrt{4} \quad 2^2 = 4
\end{array}$$

$$\begin{array}{r}
 3 \times 3 \\
 -1 \quad 0 \quad 1 = 0 \\
 0 \quad 1 \quad 2 = 3 \\
 1 \quad 2 \quad 3 = 6 \\
 \text{Total} = 9 = 3^2
 \end{array}$$

$$\begin{array}{r}
 4 \times 4 \\
 -2 \quad -1 \quad 0 \quad 1 = -2 \\
 -1 \quad 0 \quad 1 \quad 2 = 2 \\
 0 \quad 1 \quad 2 \quad 3 = 6 \\
 1 \quad 2 \quad 3 \quad 4 = 10 \\
 \text{Total} = 16 = 4^2
 \end{array}$$

$$\begin{array}{r}
 5 \times 5 \\
 -3 \quad -2 \quad -1 \quad 0 \quad 1 = -5 \\
 -2 \quad -1 \quad 0 \quad 1 \quad 2 = 0 \\
 -1 \quad 0 \quad 1 \quad 2 \quad 3 = 5 \\
 0 \quad 1 \quad 2 \quad 3 \quad 4 = 10 \\
 1 \quad 2 \quad 3 \quad 4 \quad 5 = 15 \\
 \text{Total} = 25 = 5^2
 \end{array}$$

$$\begin{array}{r}
 6 \times 6 \\
 -4 \quad -3 \quad -2 \quad -1 \quad 0 \quad 1 = -9 \\
 -3 \quad -2 \quad -1 \quad 0 \quad 1 \quad 2 = -3 \\
 -2 \quad -1 \quad 0 \quad 1 \quad 2 \quad 3 = 3 \\
 -1 \quad 0 \quad 1 \quad 2 \quad 3 \quad 4 = 9 \\
 0 \quad 1 \quad 2 \quad 3 \quad 4 \quad 5 = 15 \\
 1 \quad 2 \quad 3 \quad 4 \quad 5 \quad 6 = 21 \\
 \text{Total} = 36 = 6^2
 \end{array}$$

$$\begin{array}{r}
 7 \times 7 \\
 -5 \quad -4 \quad -3 \quad -2 \quad -1 \quad 0 \quad 1 = -14 \\
 -4 \quad -3 \quad -2 \quad -1 \quad 0 \quad 1 \quad 2 = -7 \\
 -3 \quad -2 \quad -1 \quad 0 \quad 1 \quad 2 \quad 3 = 0 \\
 -2 \quad -1 \quad 0 \quad 1 \quad 2 \quad 3 \quad 4 = 7 \\
 -1 \quad 0 \quad 1 \quad 2 \quad 3 \quad 4 \quad 5 = 14 \\
 0 \quad 1 \quad 2 \quad 3 \quad 4 \quad 5 \quad 6 = 21 \\
 1 \quad 2 \quad 3 \quad 4 \quad 5 \quad 6 \quad 7 = 28 \\
 \text{Total} = 49 = 7^2
 \end{array}$$

8 x 8	-6	-5	-4	-3	-2	-1	0	1	= -20
	-5	-4	-3	-2	-1	0	1	2	= -12
	-4	-3	-2	-1	0	1	2	3	= -4
	-3	-2	-1	0	1	2	3	4	= 4
	-2	-1	0	1	2	3	4	5	= 12
	-1	0	1	2	3	4	5	6	= 20
	0	1	2	3	4	5	6	7	= 28
	1	2	3	4	5	6	7	8	= 36
	Total = 64 = 8 ²								

9 x 9	-7	-6	-5	-4	-3	-2	-1	0	1	= -27
	-6	-5	-4	-3	-2	-1	0	1	2	= -18
	-5	-4	-3	-2	-1	0	1	2	3	= -9
	-4	-3	-2	-1	0	1	2	3	4	= 0
	-3	-2	-1	0	1	2	3	4	5	= 9
	-2	-1	0	1	2	3	4	5	6	= 18
	-1	0	1	2	3	4	5	6	7	= 27
	0	1	2	3	4	5	6	7	8	= 36
	1	2	3	4	5	6	7	8	9	= 45
	Total = 81 = 9 ²									

10 x 10	-8	-7	-6	-5	-4	-3	-2	-1	0	1	= -35
	-7	-6	-5	-4	-3	-2	-1	0	1	2	= -25
	-6	-5	-4	-3	-2	-1	0	1	2	3	= -15
	-5	-4	-3	-2	-1	0	1	2	3	4	= -5
	-4	-3	-2	-1	0	1	2	3	4	5	= 5
	-3	-2	-1	0	1	2	3	4	5	6	= 15
	-2	-1	0	1	2	3	4	5	6	7	= 25
	-1	0	1	2	3	4	5	6	7	8	= 35
	0	1	2	3	4	5	6	7	8	9	= 45
	1	2	3	4	5	6	7	8	9	10	= 55

$$\text{Total} = 100 = 10^2$$

The left side of the diagonal shall be of values - (8 x 1 + 7 x 2 + 6 x 3 + 5 x 4 + 4 x 5, 3 x 6, 2 x 7, 1 x 8) = 8 + 14 + 18 + 20 + 20

+ 18 + 14 + 8 = - 120. These values are of the format of a parabolic curve.

On the other hand the values on the right side of the diagonal including the diagonal come to be (10x 1 + 9 x 2 + 8 x 3, 7 x 4, 6 x 5, 5 x 6, 4 x 7, 3 x 8, 2 x 9, 1 x 10) = 10+ 18+24+28+ 30 + 30+ 28+ 24+18+10= 220. These values are of the format of a parabolic curve.

The pair of parabolic curves when chased and integrated set up, the same shall be adding to insight about the set up.

24. Such a chase for all the above 1 x 1 to 9 x 9 matrices format together with 10 x 10 matrix format, in their sequential formats deserve to be chased.
25. Further the above formats deserve to be chased along 1 x 1 to 10 x 10 matrix format but for the affine diagonal of value 2.
26. Likewise the set ups of affine diagonals of values 3 to 10 on their chase will be adding to further insight about the values and features of these formats.
27. Further the tabulation of the features of measuring rods of 1-space to 9-space respectively synthesized in terms of hyper cube 1 to 9 shall be of good help to workout the Vedic formats as per Vedic systems.
28. Amongst others the measuring rods admitted by dimensional domains, chase of boundaries component wise, dimensional equivalences and their coordination's with the boundaries together with the geometric ranges formats within the gaps of consecutive hyper cubes synthesizing measuring rods, duplication of boundaries, coordination of pair of gaps on either side of the hyper cube, the conversation of units from 2 to 1/2 , 3 to 1/3, 4 to 1/4 and so on, in particular will be of real help for working Vedic systems along geometric formats of hyper

cube 1, hyper cubes 1 and 2, hyper cubes 1, 2 and 3, hyper cubes 1, 2, 3, 4, hyper cubes 1, 2, 3, 4, 5 and hyper cube 1, 2, 3, 4, 5, 6.

29. Further the chase of uniqueness of each of the nine numerals of ten place value systems together with the systems of the place value system itself will be of real help for working along the Vedic systems upon Vedic formats in terms of artifices of numbers and dimensional frames running parallel to each other.

30. In particular the uniqueness of numerals and place value system may be taken for startwith chase as under :

- i. '1' is unique as it accepts only itself being its divisor.
- ii. '2' is unique as it is the only even prime numeral.
- iii. '3' is unique as it to the first odd prime numeral.
- iv. '4' is unique as it is the first composite numeral
Further $4 = 2 + 2 = 2 \times 2 = (-2) \times (-2)$ super imposition of its dimension & domain folds.
- v. '5' is unique as it is the middle placement numeral of ten placement value numerals (1, 2, 3, 4, 5, 6, 7, 8, 9)
- vi. '6' is the first perfect number $1 + 2 + 3 = 1 \times 2 \times 3$
- vii. '7' is unique as it is the biggest prime numeral of 10 place value system.
- viii. '8' is unique as it is the cube value of only even prime as that $8 = 2^3$. Further it is the only expressed for of cube value $8 = 2^3$ as the first cube value $8 = 2^3$ is so super imposed upon '1' itself as that it remains unexpressed.
- ix. '9' is unique as it is the only odd composite odd numerals.
10 is unique as it is the first double digit number and further as that it constitutes a reflection pair (10, 01) in case the numerals 1 to 9 as well are taken for their expression formats of double digit numbers as 01 to 09.

31. Further even composite numerals quadruple (4, 6, 8, 10) has summation value 28, the second perfect number.

32. Prime numerals quadruple (2, 3, 4, 5) is a manifestation layer.
33. This as such makes (2, 3, 4, 5) as the basic manifestation layer.
34. With it hyper cube 4 becomes the prime format.
35. First four primes quadruple (2, 3, 5, 7) with summation value 17 is parallel to the placement value of northern hemisphere and further it is parallel to 17 Sama.
36. Amongst others the features of the quadruple (2, 3, 5, 7) are
- i. The external circle value $2 + 7 = 9 = 3 \times 3$
 - ii. Internal circle value $3 + 5 = 8 = 2 \times 2 \times 2$
 - iii. The external circle value together with internal circle value (9, 8) constitute a vertical reflection pair (3^2 , 2^3) as here index and base digits swap their places.
 - iv. The artifices pair (14, 17) is the dimension fold and origin fold of manifestation layer (14, 15, 16, 17) with equal values for its external circle and internal circle which come to be '31' parallel to the linear order set up and further parallel to 31 geometric component of cube, hyper cube 3.
 - v. $31 + 31 = 62$ is the unique position of attainment of duplication of cube along a manifestation format of hyper cube (16) of manifestation layer (14, 15, 16, 17) with summation value 62 and as such it may be designated as the cosmic layer with the feature that spatial order transcends to 6-space with 2-space being the dimension of dimension of 6-space.
 - vi. Hyper cube 16 with boundary components 32 and dimensional coordination value 16×14 , that way leads to the working units 7 and $1/7$ which is a unique attainment.
 - vii. With this artifices 4 and 7 acquire unique pairing as that artifices range (1, 2, 3, 4, 5, 6, 7) and parallel to it spaces range (1, 2, 3, 4, 5, 6, 7) and still further parallel to it hyper

cubes (1, 2, 3, 4, 5, 6, 7) accepting organization along 4 x 4 format will be helping having organization of Vedic knowledge in spatial order creator's space (4-space), in such a way that it of its own shall be transiting and transforming into transcendental format of 5 x 5 format of hyper cube 5 format organization within creator's space.

Chase Step – 80
UPVEDAS

37. Transcendental code value for the formulation 'उपवेद Upved' = 42 shall be providing us enough leads.
38. The focus here would be shifting 1^3 to 2^3 .
39. The chase with 2^3 as a unit shall be a shift from cube of cube 1 x 1 x 1 to cube 2 x 2 x 2.
40. Cube 1 x 1 x 1 in terms of 1 / 2 as unit shall be helping us reach at cube as a set up of 8 sub cubes.
41. On the other hand working with the unit 2 as 1 shall be taking us from cube to 8 cubes.
42. The organization of Rigved, amongst others is of the features as that it is organized as 8 austaks and simultaneously it is organized as 64 chapters.
43. This reach from 8 to 64 for the same range would take from a cube to its 8 sub cubes which further accept 8 sub sub cubes for each sub cubes.
44. The other organization of eight cubes synthesizing as a cube and simultaneously each of those cubes splitting into 8 sub cubes, as such is to be taken as an expression for a parallel reach for both approaches firstly of a reach from cube to eight sub

cubes to 64 sub sub cubes and secondly as 8 cubes with each of 8 sub cubes synthesizing as a cube.

45. The above reach for pair $(1^3, 2^3)$, and further $2^3, 3^3$ and also as $1^3, 2^3, 3^3$ and still further $1^3, 2^3, 3^3, 4^3$ with $4^3 = 2^2 \times 2^2 \times 2^2$ shall be providing us an insight as to the chase of cubes of different sides values (1, 2, 3, ----).
46. The Sama Veda with 1000 branches as a set up of 1000 cubes organized as $10 \times 10 \times 10$ and further as $(1+2+3+4)^3$ and will add to our insight as to how pure values and applied values run parallel to each other.
47. Rik as a line as a dimension fold and also a domain fold can be worked out as pure values format as well as of applied values format.
48. Likewise Yaju and Sama as well as Ahtrava are having integrated formats for simultaneous chase of pure and applied values.
49. It is the super imposition of dimension fold and domain fold at the base of the formats and systems leading to distinct chase for dimension fold as well as of domain fold while working with their super impositions.
50. This in a way in reference to formulation ऋक with TVC value 5 shall be focusing upon artifices pair (3, 5) with summation value $(3+5) = 8$ and thereby there would be a shift from hyper cube 3 and 5 to hyper cube 8 with 16 boundary components and 48 dimensional equivalence value yielding $1/3$ and $3/1$ as working units in terms of which hyper cube 3, hyper cube 5 and hyper cube 8 formats can be simultaneously worked out along hyper cube 4 format itself at its boundary of eight components accepting $2 \times 8 = 16$ coordinates with split as $16 = 7 + 9$ such that artifice 7 value is parallel to 7 geometries range of 3-space and further parallel to the gap value between hyper

cube 3 and hyper cube 4 and further as that artifice 9 value is parallel to 9 geometries range parallel to gap value between hyper cubes 4 and 5.

51. This will help have a chase for Rigved and its Upved namely Ayurved.
52. Likewise Yajurved and its upved as well as Samved and its Upved organizations will permit a chase.
53. Atharaved and its upved namely Sathapatya ved, in particular with their chase will add further insight for the chase of organization formats of Rig, Yajur and Sama Vedas and their Upvedas.

*

Chase Step – 81
RIGVED

54. Rigved is the first Ved.
55. Ayurved is the upved of Rigved.
56. Rigved has 21 branches.
57. Each branch of Rigved has distinct samhita, Brahmana, Arnik and Upnished. This makes Rigved being a set of 84 scriptures
58. Rigved being the first Ved. It as such accepts features of artifice '1'. However it being the first of the four Vedas being re-organization of single wholesome Ved, as such the features of artifice '1' are approached as '1 as 4' and '4 as 1'.
59. This, this way makes it an organization permitting chase in terms of unit '1/4' and as mathematics of 4/1 and 1/4 available simultaneously.

60. Om Itah Ex akshar Braham ॐ इति एक अक्षर ब्रह्म focuses upon the features of ॐ Om as '1' as well as '4'.
61. Om Tat Sat Itah Nirvesha focus upon the chase rule of the organization of ॐ 'Om' as of features '1 as 4' and '4 as 1' as that '4' permitting chase as '1 to 4' and '3 as transiting and transforming into 4'.
62. This brings to the format of the spatial order 4-space / hyper cube 4 as manifestation format with feature of permissible transcendence at origin fold.
63. Hyper cube 4 as four fold manifestation layer (2, 3, 4, 5) / (2-space as dimension fold, 3-space as boundary fold, 4-space as domain fold and 5-space as origin fold is of the manifestation features that 4-space content gets enveloped within solid boundary of eight components
64. The further features of such manifestation is that the external circle summation value $(2 + 5) = 7$ and internal circle summation value $'3+4' = 7$ focus upon the artifice value '7'.
65. This feature of boundary permitting split in eight parts and internal and external circles value being '7' and these together as $7 + 8 = 15 = 1 \times 3 \times 5$ equal to linear dimensional equivalence value for 5-space, deserve to be chased for comprehension and imbibing of this format to have an insight about the basic chase features of the Discipline of Vedic Mathematics, Science and technology. These features take us to the center of cube / origin of 3-space being the seat of 4-space where corner of 8 sub cubes meet and get synthesized as a set up of 9 points.
66. It is this collapse of eight points upon ninth point which as such is to be taken as the starting point for the chase of creations range at center of the cube / origin of 3-space being 4-space.
67. The center of cube becomes the structured point.

68. The chase as such is to be there in terms of this structured point.
69. The center of cube / origin of 3-space / 4-space as structured point is infact the compactification / compactified point of whole range of origins / origin folds of whole range of hyper cubes.
70. Center of cube / origin of 3-space / 4-space point body shall be taking us to zero value artifice
71. This reach from linear order point to spatial order point is of pair of orientations, first of which shall be taking us back from artifice 1 to artifice 0 and secondly from artifice 0 to artifice 1
72. It is this range of two fold transition as a triple (-1, 0, 1) shall be leading us to number of features, of which prominent one would be of a set up of a bend at the middle and there by there being a two dimensional frame of half dimensions.
73. It is this feature of reach which also shall be taking us to a two way approach to the middle (from either end) here in the context of the triple) which that way would be providing a set up of the format of the triple (1, 2, 1)
74. Still further this triple (1, 2, 1) also would be leading us to a paired pair [(1, 2) and (2, 1)]
75. It is the working with one of this paired pair and simultaneously along with both the pairs of this paired pair is going to settle the structural format in terms of which a chase of spatial order 4-space and ahead a transition therefrom to the solid order transcendental domains (5-space as domain) can be reached at.

76. The pair (1, 2) and also (2, 1) and parallel to that a pair of (line, surface) / (1-space, 2-space), shall also be helping us have a chase as a horizontal surface together with a vertical line which shall be providing a chase format for a 3-space / solid set up as well.
77. Let us have a pause here and have a fresh look at the above features and have recapitulation for fresh comprehension and imbibing of the values for an insight of the spatial order structural chase of creator's space (4-space) with beginning as a zero value at center of the cube / origin of 3-space
78. This start with 0 value / 0-space, as dimensional fold shall be leading us to structured set up of hyper cube 2 / 0 space in the role of dimension fold and 2-space in the role of domain fold.
79. This reach from artifice value 0 to artifice value 2 and parallel to a reach from 0 --space as dimension fold to 2-space as domain fold, shall be further helping have a reach at the set up of the spatial order 4-space / hyper cube 4 with 5-space in the role of origin fold
80. This attainment from artifice value 0 to artifice value 2, and ahead to artifice value 5, shall be also helping us comprehend as that because of the spatial order (2-space) in the role of dimension, reach to the origin fold (5-space) / artifice 5 here would be in repeated format because of pair of dimensions of the spatial order and that way the attainment of artifice value 5 is going to be twice, that is as artifice value 5 followed by artifice value 5.
81. The role of 5-space as dimension fold, as such shall be leading us to the structural features of the origin fold in case of 5-space in the role of origin being as of a pair of values of 5, 5 which shall be providing enveloping for 5-space in terms of ten boundary components, each being of creative order (4-space content lumps / domain with 5-space as origin).

82. This attainment shall be leading to a reach at artifice value '10'
83. Let us again have a pause here and permit the transcending mind to be face to face with the sequential attainment steps which take us firstly from artifice value 2 secondly which take us to artifice value 5, thirdly which again us to artifice value 5 and fourthly the attainment of artifice value 10
84. These sequential attainment values of artifices organized and chased along placement value format shall be as quadruple (2, 5, 5, 10) along its reverse orientation shall be attaining artifice value (10552)
85. It is this attainment as of 10552 components which is the attainment of Rigved Samhita
86. This value of artifice 10552 is parallel to 10552 richas of Rigved samhita
87. These richas are organized as 1028 suktas which themselves are organized as ten mandals as per the following tabulation

Sr	Mandal	Suktas	Total	Richas	Total
I	1	191	191	2006	2006
II	2	43		429	2435
III	3	62		617	3052
IV	4	58		589	3641
V	5	87		727	4368
VI	6	75		765	5133
VII	7	104		821	5954
VIII	8	103		716	6670
IX	9	114		1108	7778
X	10	191		2774	10552

Total	10	1028		10552	

88. The chase of organization of Rigved Samhita text lead us to following features

It has 21 branches.

Artifice 21 has $21 = 1 + 2 + 3 + 4 + 5 + 6$. It is parallel to the features of Sathapatya measuring rod synthesized as hyper cube 1 to hyper cube 6 with Lord Vishnu, overlord of 6-space as presiding deity of the measuring rod.

With it the organization takes to 6-space / hyper cube 6 / Sun / Pursha format / Vishnu lok. Further artifice 21 also accepting organisation as $10 + 01 + 10$ which is parallel to artifice triple (10, 01,,10) accepting re-organization as paired pair (10, 01), (01, 10). This as focuses upon the features of artifices 01 and 10 which otherwise constitute a reflection pair.

Still further it leads to pairing of features of 6-space and 1-space and parallel to it artifices pair (6, 1) and also to pairing of hyper cube 6 and hyper cube 10 and parallel to it pair of artifices (6, 10) / (6, 6 + 4), which as such shall be leading to the features of super imposition of 4-space as dimension fold upon 6-space as domain fold.

ii. The second feature of the organization of Rigved Samhita takes us from the format of 6-space / Sun to 5-space / transcendental domains / hyper cube 5.

The feature of hyper cube 5 as that transcendental domains (5-space) as domains are enveloped within ten components of creative domain (4-space) as domain boundary formulation ratio is $A^5:10B^4$ and parallel to it is the

organization feature of Rigved Samhita text as that it is organized as 10 mandals

- iii. The third feature of the organization of Rigved Samhita takes us from 5-space set up to 4-space as 4-space is enveloped within solid boundary of 8 components and parallel to it Rigved Samhita text is organized as 8 austsaks.
- iv. Fourth feature of Rigved Samhita takes us from 4-space to 3-space as cube accept split into 8 sub cubes which further shall be having into a split into $8 \times 8 = 64$ sub sub cubes and parallel to it there is organization of Rigved Samhita as 64 Adheyes / chapters
- v. Fifth feature of organization of Rigved samhita takes us to spatial boundary of 3-space which is synthesized as surface plates, edges and corner points.

These three constituent of boundary of 3-space / boundary fold set up of hyper cube 3 focus upon a reach for 3-space in terms of single, double and triple dimension as those synthesized geometric envelope for a cube

The format of a surface as a set up of pair of dimensions (and edge) as of the format of a single dimension, together are of feature parallel to 1028 suktas organization of Rigved Samhita.

The organization format of edge / single dimension as hyper cube 1 with spatial origin, as such as of 2024 features is parallel to organization of Rigved Samhita text as of 2024 vargas.

The corner points as for its role as zero dimension fold of manifestation layer (0, 1, 2, 3) shall be of 10552 components range parallel to 10500 richas constituting text of Rigved Samhita.

The corner points of cube are embedded with 3 dimensional frame of half dimensions. This as such shall be leading us to the attainment of transcendental domains by the richas of Rigved .

Each Richa of Rigved unfolds parallel to unfolding of the collapse of corner points of 8-sub cubes as center of the cube as origin seat of 4-space within 3-space.

Each Richa as such shall be having structural frame of the organization format of four fold formulation namely (Rishi, Devta, Chandas and Swara) the transcendental code value of these formulations manifesting along diagonal of square as linear diagonal format, of cube as a spatial diagonal format, of hyper cube 4 as solid diagonal format and of hyper cube 5 as creative diagonal format. Parallel to it would be the quadruple values (2, 3, 4, 5) and also in the reverse dimensional order formats as to be quadruple values (6, 5, 4, 3)

This pair of quadruple values (2, 3, 4, 5) and (6, 5, 4, 3) shall be ultimately helping reach as the organization format components for the chase and reach at Richas as of values quadruple (6 x 2 =12, 3 x 5= 15, 4 x 4 = 16, 5 x 3 =15)

This values quadruple (12, 15, 16, 15) has external encircling value $27 = 12 + 15$ and internal encircling value $31 = 16 + 15$ and the total summation value $27 + 31 = 58$ which constitutes a reflection pair as (58, 85) with further summation value $58 + 85 = 143 = 11 \times 13$, an organization format of 11 x 13 matrix format for 12 place value system, an attainment which deserves to be chased for geometric format features thereof and same shall be leading to :

- i. Artifices pair 58 and 85 with place value digits 8 and 5 with artifice $8 = 3 + 5$ shall be leading to the features of inter coordination of hyper cube 5 and

hyper cube 8 with 3-space in the role of dimension of 5-space having super imposition of dimension fold and domain fold in the set up of hyper cube 8 having boundary components $8 \times 2 = 16$ and dimensional coordinates $8 \times 6 = 48$ leading to units pair $(3/1, 1/3)$ in terms of artifices pair $(16, 48)$.

- ii. Further as that, $9 = 3 \times 3$ and $8 = 3 + 5$ shall be leading to features parallel to 8 corner points synthesizing at center of the cube (9th point) and there being a transition to second phase spatial order (3×3) . Here it also would be relevant to note that $9 = 3^2$ and $8 = 2^3$ is also constituting a reflection pair $(3^2, 2^3)$ where index and base values are swapping their places.
- iii. $58 = 13 + 14 + 15 + 16$ and quadruple $(13, 14, 15, 16)$ as manifestation layer of hyper cube 15 will ultimately workout transcendental values formulations Devta देवता and Swara स्वर and the chandas छंदस formulation as origin fold of hyper cube 15 as a second phase manifestation is to take us to manifestation layer $(4, 5, 6)$ with $4 = \text{under root } 16$ and $4 + 5 + 6 + 7 = 22$, the transcendental code value for formulation छंदस Chandas.

*

Chase Step – 82
YAJURVED

1. Yajurved is the second ved.
2. Yajurved samhita is a scripture of 40 chapters.
3. Dhanurved is the upved of Yajurved.

4. Formulation 'Yaju' accept simple English rendering as 'rope' / cord.
5. Fiber manifesting as cord / rope, all are the features, which will lead us to the features 'yaju'.
6. The manifestation layer (2, 3, 4, 5), being the second manifestation layer and being of a spatial order accepts creator's space (4-space) as a domain fold with transcendental origin (5-space in the role of origin).
7. The transition from the role of 4-space as domain fold to role of 4-space as boundary fold is the feature which deserves to be chased for comprehension and insight about the organization of this range of knowledge.
8. 4-space as domain fold and playing the role of boundary fold is of the features, whose chase will help us comprehend and to have an insight as to how spatial order domain accept role of a boundary fold and the resultant features deserve to be comprehended well.
9. TCV (यजुर्वेदः) = 1 + 1 + 2 + 4 + 3 + 20 + 13 = 44 deserve to be comprehended in reference to TCV (ऋग्वेदः) = 4 + 3 + 20 + 13 = 40 and TCV (सामवेदः) = 3 + 2 + 9 + 1 + 20 + 13 = 48.
10. Artifices triple (40, 44, 48) accept re-organization as 10 x 4, 11 x 4, 12 x 4.
11. One may have a pause here and permit the transcending mind to chase NVF (Plank) = NVF (Plan) + NVF (k) = 43 + 11 = NVF (frame) + NVF (Bed) = NVF (Sun).
12. Here it would be relevant to note that artifice 11 is parallel to 11 geometries range of 5-space.

13. Further as that NVF (light)= 56. It is going to be a chase from 6-space to 5-space. The chase is going to be along 11 geometries range of 5-space. And this 11 geometries range of 5-space is there because of the creative boundary (4-space as boundary) of ten components of transcendental domain (5-space).
14. All these features as such focus upon 'frame / boundary (fold)' with NVF (folds) = 56= NVF (light).
15. TCV (यज्ञः) = 1 + 1 + 4 + 6 + 1 + 13 = 26 = 5 + 6 + 7 + 8 / (5, 6, 7, 8) / (hyper cube 7), is the transcendental values feature of transcendental order (5-space in the role of dimension).
16. Single dimension as dimension fold, pair of dimension as boundary fold, triple dimension as domain fold, quadruple dimension as origin fold and five dimensions as transcendental base are the feature which deserve to be chased to have insight about the range of knowledge of Yajurveda.
17. TCV (धनुर्वेदः) = 7 + 1 + 2 + 8 + 3 + 20 + 13 = 21 + 20 + 13 = 54 = 6 x 9 as outer circle value of the manifestation layer (6, 7, 8, 9) and 7 x 8 = 56 as inner circle value will help us chase artifices pair (54, 56) as domain fold and dimension fold values with 54 + 56 = 110 = NVF (Sunlight) = NVF (Meditation) = NVF (Sky, Sky) and in terms of this chase the distinct features of yajurved will come to focus about coverage of Earth to Sun range in terms of 26 meters as transcendental filters as carriers within rays of the Sun.
18. TCV (धनु) = 21 = 1 + 2 + 3 + 4 + 5 + 6 is organization parallel to the organization of Sathpatya measuring rod of formats of hyper cube 1 to 6.
19. NVF (fiber) = NVF (cord) = NVF (line) = NVF (mind) = 40 = 4 x 10 = 40 coordinates required for coordination of creative boundary of ten components.

20. Yajurved accepts 101 branches.
21. Artifice 101 accept re-organization as $101 = 10 \times 10 + 01 \times 01$.
22. Artifices pair (01) x (10) is a reflection pair.
23. Along a straight line 10 points sustain 9 linear units also 9 points sustain 11 linear units. It is only along circumference of a circle that ten point sustain 10 linear units.
24. These feature will help comprehend and to have an insight about yajurveda being of 101 branches.
25. Further the transition and transformation from artifice 1 to artifice 2 will help us comprehend as to how silently the attainment comes to be of simultaneous availability of values and features of artifice 1 as well as of artifice 2 and thereby there being the attainment of the features of artifice 3.
26. It is this feature which will help us comprehend and to imbibe the features of 'यर्जुः' as line, fiber, cord and also that the same shall be of artifice value '54' as TCV (धनुर्वेदः) and as that NVF (Sun) = 54.
27. This feature of synthesis of pair of linear dimensions being '3' and in general the synthesis value of pair of dimensions of order n leading to 'n + 2' value deserves to be comprehended well and to be imbibed fully to have proper insight of mathematics, science and technology of synthesis of dimensional axis.
28. It would be blissful to comprehend and to imbibe this feature which shall be leading us to synthesis value of triple dimension of any order being '6', which is the number / artifice of 'Sun / सूर्यः'

29. Here it would be relevant to note that (3, 4, 5, 6) leads to 6-space in the role of origin fold.
30. Further TCV (सूर्यः) = 26 (5, 6, 7, 8) with 6-space being in the role of boundary fold.
31. 6-space in the role of boundary fold of hyper cube 7, the format of 7-space body (pole star) and that this attainment being of 26 meters range, is the blissful comprehension of the Vedic systems. Therefore all these features leads us to simultaneous appreciation of
- i. Manifestation layers format
 - ii. Number value formats
 - iii. Transcendental code value
 - iv. Dimensional synthesis values

32. The dimensional synthesis values table which was given at the outset of the course is being reproduced again for its proper comprehension and for imbibing its values to have proper insight about the Vedic systems functional approach for coverage of Earth to Sun range along the transcendental carriers of Sun light:

C1	C2	C3	C4	C5	C6	C7	C8	C9
-9	-7	6	30	65	111	168	226	315
-8	-6	6	28	60	102	154	206	288
-7	-5	6	26	55	93	140	196	261
-6	-4	6	24	50	84	126	176	234
-5	-3	6	22	45	75	112	156	207
-4	-2	6	20	40	66	98	136	180
-3	-1	6	18	35	57	84	116	153
-2	0	6	16	30	48	70	96	126
-1	1	6	14	25	39	56	76	99
0	2	6	12	20	30	42	56	72

↑	-1	-1	0	+2	+5	+9	+14	+20	+27
↓	+1	+1	0	-2	-5	-9	-14	-20	-27

1	3	6	10	15	21	28	36	45
2	4	6	8	10	12	14	16	18
3	5	6	6	5	3	0	-4	-9
4	6	6	4	0	-6	-14	-24	-36
5	7	6	2	-5	-15	-28	-44	-63
6	8	6	0	-10	-24	-42	-64	-90
7	9	6	-2	-15	-33	-56	-84	-117
8	10	6	-4	-20	-42	-70	-104	-141
9	11	6	-6	-25	-51	-84	-124	-168

*

Chase Step – 83
SAMVED

1. Samved is the third Ved.
2. Samved has one thousand branches.
3. With it artifices 3 and 10^3 lead to features of organization format of Samved knowledge.
4. Gandharav ved is the upved of Samved
5. Transcendental code values of formulations ‘सामवेदः’ and ‘गंधर्ववेदः’ will help reach at basic features of this organization of knowledge.
6. TVC (सामवेदः) = $15 + 20 + 13 = 48 = 2 \times 4 \times 6$ which is Parallel to two phased transcendence from 6-space (Sun) to creator’s space (4-space) to spatial order (2-space).
7. This two phased transcendence phenomenon, as such becomes the basic organization chase feature of this range of knowledge.

8. TCV (गंधर्ववेदः) = (3 + 1 + 8 + 7 + 1 + 2 + 7 + 1) + (20 + 13) = 30 + 20 + 13 = 63.
9. TCV (गंधर्ववेदः) = 30 = TCV (द्रव्यः) = TCV (दिव्यः) and the same is further parallel to 13 components set up of cube together with its 3 dimensional frame as '3' dimensions + 8 corner points + 12 edges + 6 surfaces + 1 volume.
10. TCV (गंधः) = 20 + 13 = TCV (वेदः).
11. TCV (नादः) = 30 = TCV (वेदः)
12. These formulations will help impress for the need for compiling of Samved text formulations of equal TCV values to reach at the pure and applied values of this range of knowledge. The organization of artifices 1 to 1000 as a range (01)³ to (10)³ on its chase will help us comprehend and to imbibe the features of organization of this range of knowledge as 1000 branches.
13. Atharavved with its 9 branches organizes 01 to 99 as a range of 99 double digit numbers along the 9 x 11 matrix format availing 9 geometries range of 4-space and 11 geometries range of 5-space. This double digit numbers organization of ten place value system along (10 -1) x (10+1) matrix format with grid base 1 x 1 would help organization of triple digit numbers of ten place value system along the 'three dimensional shell (10-1) x 10 x (10 + 1) with shell base 1 x 10 x 1.
14. Shell 9 x 10 x 11 would permit re-organization as 720 + 270 and further 772 = 6 x 120 and 270 = 3 x 90 will help reach at triple digits numbers around shell based of ten triples of equal digit values, viz (000, 111, 222, 333, 444, 555, 666, 777, 888, 999).
15. The triple digit numbers with a pair of them being identical shall be 90 basic triples with each triple having three distinct formations. Likewise 720 triple digit numbers shall be

basic of them being 120 only with each such basic triple of all three of them are distinct would be of six distinct formation each.

16. The tabulation of these $120 + 90 = 210$ basic triple digit formulations comes to be :

Triples with pair of digits being equal

There are 10 distinct digits namely '0, 1, 2, 3, 4, 5, 6, 7, 8, 9'.

These ten digit shall be leading to ten double digit numbers of equal digits namely '00, 11, 22, 33, 44, 55, 66, 77, 88, 99'.

Each of these ten double digit numbers of equal digit, shall be constituting a range of 9 distinct triple digit number and thereby there would emerge $9 \times 10 = 90$ such distinct triple digit numbers with pair of digits being equal. The tabulation comes to be as under:

Sr	Equal digits pair	First triple	Second Triple	Third triple	Fourth triple	Fifth triple	Sixth Triple	Seventh Triple	Eighth triple	Ninth triple
1	000	001	002	003	004	005	006	007	008	009
2	111	110	112	113	114	115	116	117	118	119
3	222	220	221	223	224	225	226	227	228	229
4	333	330	331	332	334	335	336	337	338	339
5	444	440	441	442	443	445	446	447	448	449
6	555	550	551	552	553	554	556	557	558	559
7	666	660	661	662	663	664	665	667	668	669
8	777	770	771	772	773	774	775	776	778	779
9	888	880	881	882	883	884	885	886	887	889
10	999	990	991	992	993	994	995	996	997	998

17. Each of the above 90 triple digit numbers shall be accepting three adaptation each like (001, 010, 100) for 001 and (110, 101, 011) for 110 and so on.

18. Triple digit numbers of distinct three digits shall be 120 basic triples and as each of such like triple shall be adaptation six triples each. So such range would be of 720 range of triple digit numbers.

19. The tabulation of these 120 basic triple of distinct digits can be grouped as (8, 7, 6, 5, 4, 3, 2, 1) = 36, (7, 6, 5, 4, 3, 2, 1) = 28, (6, 5, 4, 3, 2, 1) = 21, (5, 4, 3, 2, 1) = 15, (4, 3, 2, 1) = 10, (3, 2, 1) = 6, (2, 1) = 3, (1) = 1. This organization as summation $120 = 36 + 28 + 21 + 15 + 10 + 6 + 3 + 1$ is parallel to linear dimensional synthesis of one dimension, two dimensions, three dimensions, four dimensions, five dimensions, six dimensions, seven dimensions, and eight dimensions respectively.

20. Group of 36 triple digits of distinct digit are as under

012	023	034	045	056	067	078	089	8
013	014	015	016	017	018	019		7
024	025	026	027	028	029			6
035	036	037	038	039				5
046	047	048	049					4
057	058	059						3
068	069							2
079								1
								36

21. Group of 28 triple digits of distinct digit are as under

123	134	145	156	167	178	189	7
134	135	136	137	138	139		6
145	146	147	148	149			5
156	157	158	159				4
167	168	169					3

178	179						2
189							1
							28

22. Group of 21 triple digits of distinct digit are as under

234	235	236	237	238	239	6
245	256	267	278	289		5
256	257	258	259			4
267	268	269				3
278	279					2
289						1
						21

23. Group of 15 triple digits of distinct digit are as under

345	346	347	348	349	5
356	357	358	359		4
367	368	369			3
378	379				2
389					1
					15

24. Group of 10 triple digits of distinct digit are as under

456	457	458	459	4
467	468	469		3
478	479			2
489				1
				10

25. Group of 6 triple digits of distinct digit are as under

567	568	569	3
578	579		2
589			1
			6

26. Group of 3 triple digits of distinct digit are as under

678	679	2
689		1
		3

27. Group of 1 triple digits of distinct digit are as under

789	1
	1

28. The organization of artifices 000 to 999 / 0001 to 1000, there is an organization of cube $10 \times 10 \times 10$ as a synthetic set up of 1000 cubes. The structural chase of cube as 1000 sub cubes will provide us a base for 1000 branches of Samved. The focus of Samved is upon 'द्रव्यः' / content. It is distinct than 'पदार्थः' / matter. TCV (पदार्थः) = $22 + 13$. The artifice 22 accept re-organization as $22 = 4 + 5 + 6 + 7$ and parallel to it there is a manifestation layer (4, 5, 6, 7). Further the artifice 35 accepts re-organization as 5×7 which is parallel to the dimensional frame of 7-space. This way the chase comes to be of the format of hyper cube 6 with 7-space in the role of dimension of origin. On the other hand TCV (द्रव्यः) = $30 =$ TCV (दिव्यः) and artifice 30 accept re-organization as $30 = 6 + 7 + 8 + 9$ and parallel to it there is manifestation layer (6, 7, 8, 9) of hyper cube 8 with 9-space in the role of origin.

29. Further it would be relevant to note that $8 = 3 + 5$ and also $8 = 2^3$ and $9 = 3^2$ are the features which on their chase shall be giving us an insight about 6-space in the role of dimension and further about the super imposition of solid dimensional order 3-space content upon transcendental domain (5-space).

30. The structural frame and systems of Samved Samhita, as such will take us to advance stage course. However a glimpse of the way the processing will unfold is being touched will

continue unfolding is being touched for few steps and the same is going to be on the following lines:

- i. The Purva Archik, the first part of Sama Veda Samhita, very precisely works out Sun as a six dimensional domain. The six chapters division of Purva Archik is in unison with the six dimensional domain structural base of the Sun. Further division of 64 Dastis for chapter 4, 11 Dastis for chapter 5, and 5 Dastis for chapter 6 is precisely as a Divya Ganga flow of the Tejas from core of the Sun through four components of the Om formulation ending up into the core of the Avvyakto-Avyaktat. This processing model helps us very precisely to calculate the mantras of the each of the six chapter of the Purva Archik.

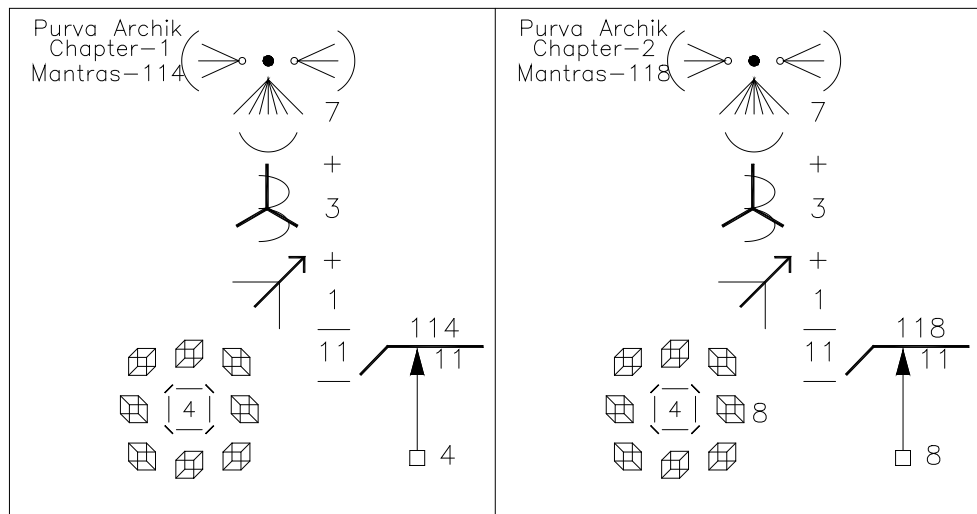

- ii. The above chart indicates the flow of the Tejas from the core of the Sun as Divya Ganga into core of the Avvyakto-Avyaktat through its frame. The frame of the fifth dimensional domain is the fourth dimensional domain. As such, while the chapter 1 has 114 mantras and the chapter 2 is having 118 mantras. Chapter -1 takes us from the fourth dimensional domain to the 11 components of the Divya Ganga flow. The chapter -2 takes from the frame of fourth dimension that is from eight cube to the 11 components through the Divya Ganga flow. Chapter 1 is a

scripture of 114 mantras and the chapter 2 is a scripture of 118 mantras.

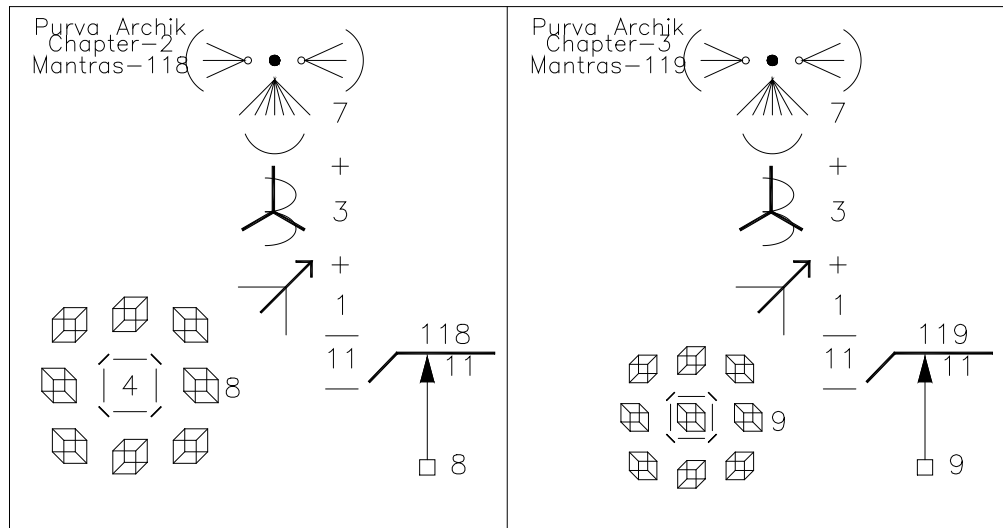

- iii. Chapter 3 is a scripture of 119 mantras as at origin point/Nabhi/ core of the fourth dimensional domain, also can be embedded a cube structure, a ninth cube as seat of the Brahm. Tins when connected with 1 1 components of Divya Ganga flow would work out 199 mantras scnpture composition of chapter-3, while from fourth dimensional domain to the Divya Ganga components we would be having structures of 114 mantras for chapter-1, while from eight cubes frame to the 11 components of Divya Ganga would be having 118 mantras for chapter 2, while from the core of the fourth dimensional domain to 11 components of Divya Ganga, we would be having 199 Mantras for chapter 3.

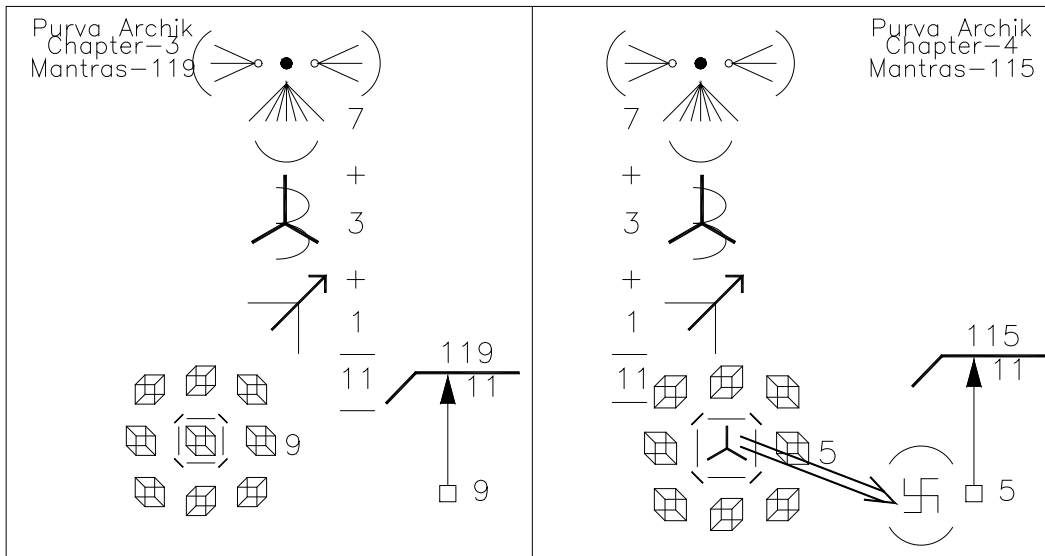

- iv. Now from the core of the fourth dimensional domain the flow naturally would be to the fifth dimensional domain. While the fifth dimensional domain is connected with the 11 components of Divya Ganga, it would account for 115 mantras basis for division of the text of fourth chapter of the Purva Archik of the Samved.

PURVA ARCHIK CHAPTER 5: MANTRAS 119

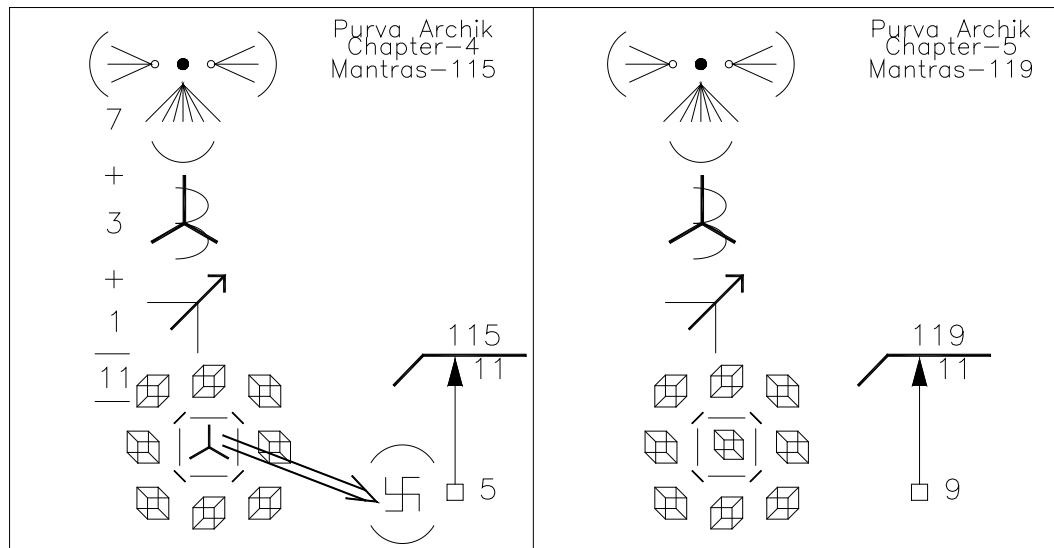

- v. With this the fourth dimensional domain revolves and proceeds to other side of the Avyakto-Avyaktat, the fifth dimensional domain. The fourth dimensional domain would proceed to other side of the fifth dimensional

domain and as such while we connect the Divya Ganga flow of I I components with nabhi, the core of the origin point of the fourth dimensional domain, it would account for 119 mantras basis of the division of the text of the fifth chapter of Purva Archik of the Samved.

- vi. We may understand that fifth dimensional domain is the Avyakto Avyaktat around which revolves the fifth dimensional domain. The fourth dimensional domain is the domain which is framed by eight cubes. The ninth cube structure is admissible at the Nabhi of the fourth dimensional domain. The fourth dimensional domain with cube structure at its origin point while one the one side of the fifth dimensional domain contributes and accounts for 119 mantras basis for division of chapter 3 and the fourth dimensional domain while proceeds on other side of the fifth dimensional domain, it accounts for 119 mantras basis division of the text of the fifth chapter of the Purva Archik of the Samaved.

PURVA ARCHIK CHAPTER 6: MANTRAS 119

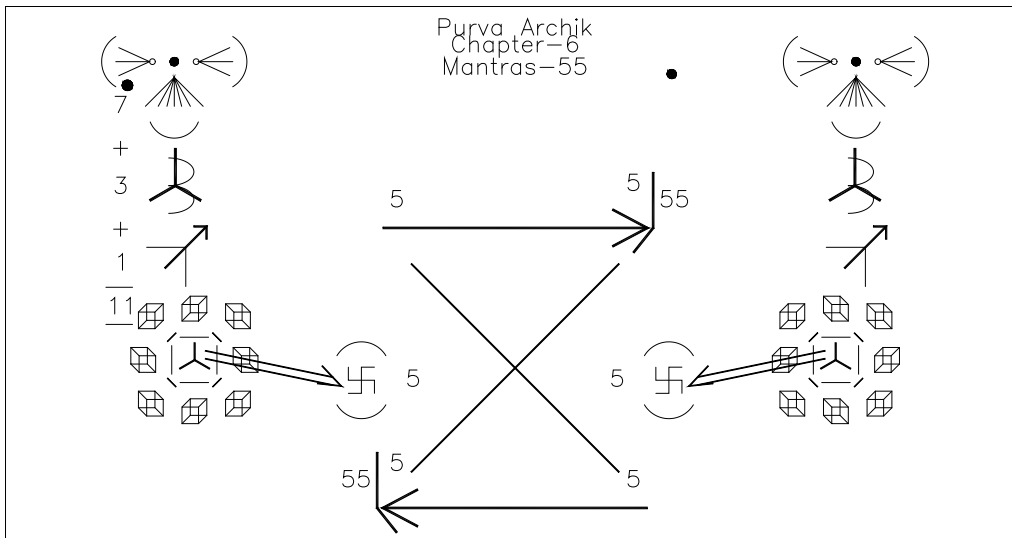

- vii. This division of the text makes out that fifth dimensional domain, i.e., the Avyakto Avyaktat is the domain which is sealed on both sides. Fifth dimensional domain is the

domain around which revolves fourth dimensional domain. This domain being the domain which is sealed on the both sides and when the both facets of the fifth dimensional domain stand coordinated, as is visible, it would contribute 55 mantras basis for division of the text of the sixth chapter of the Purva Archik of the Samved.

- viii. Fifth dimensional domain is the domain which revolves around the Sun. Sun admits six dimensional domain. At the core of the Sun i the seat of the Brahm. Brahm is the ultimate. With this the structural frames & systems of the Purva Archik completes processing as a six dimensional domain processing for the Sun.

MAHAMNYA ARCHIK: A single chapter scripture

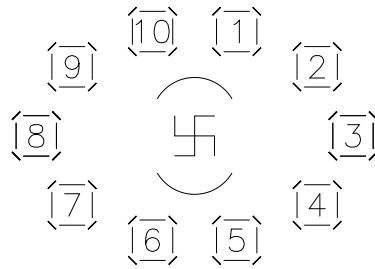

- ix. The second and third parts of the Samved carry forward this processing model. The processing upto this stage comes to be the processing of the Sun as a six dimensional domain and the Tejas flow from core of the six dimensional domain on four components of Om formulation into the core of the fifth dimensional domain.

SUM-UP

- x. It may be summed up that Samaveda is the third Veda. Samaveda admits structural frames & systems in unison with the structural frames & systems of natural number 3.
- xi. Samaveda like other Vedas is written on the rays of the Sun. Samaveda is the Veda which works out the Tejas

flow as Divya Ganga through four components of the Om formulation ending up into the core of Avyakto Avyaktat.

- xii. The processing model of the Samaveda is the processing which connects core of the Sun with the core of the Avyakto Avyaktat through four components of Om formulation as Divya Ganga flow of Trjas fountained from the core of Sun into the core of the fifth dimensional domain. Sun as six dimensional domain admits frame of fifth dimensional domains. Fifth dimensional domain revolves around the Sun as six dimensional domain. Fifth dimensional space is the domain which is framed by ten fourth dimensional domains. Ten fourth dimensional domains revolve around a fifth dimensional domains. Ten four dimensional domains constitute Dasti, a block of ten framed domains. Fourth dimensional domain is the domain which is framed by eight cubes. The fourth dimensional domain is the domain which ultimately becomes the basis of the individual mantras of the Samaveda.
- xiii. The Purva Archik, the first part of the Samaveda is a scripture of six chapters. The division of the Purva Archik scripture as six chapters in unison with the six dimension of the six dimensional domain of the Sun. The Purva Archik is a scripture of 64 dastis. Dasti, we can recapitulate, is a block of ten mantras, a block of ten four dimensional domains. The ten four dimensional domains frame a fifth dimensional domain. Fifth dimensional domain is the Avyakto Avyaktat into whose core stands fountained the Tejas from core of the Sun.

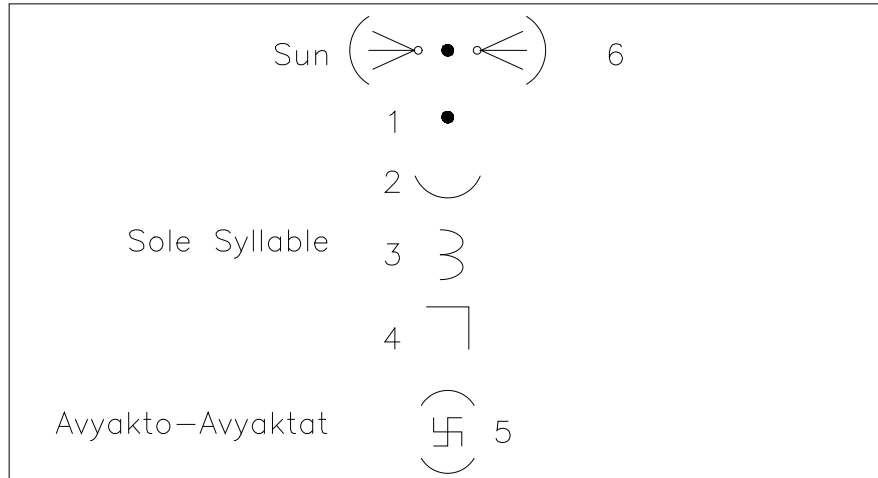

xiv. Now we are taking up Samaveda for understanding the basis on which Mantras of different Dastis of the six chapters of Purva Archik of Samaveda are settled. Samaveda is the third Veda. Vedas are written on the rays of the Sun. Sun admits six dimensional domain. Six dimensional domain is the domain around which fifth dimensional domain revolves. Purva Archik is the scripture of six chapters. However we shall be taking up only chapter 1 here firstly for its organisation as 12 Dastis and then for its organisation as mantras of each Dasti. The processing can be extended for all other chapters of Purva Archik as well as for other Archiks

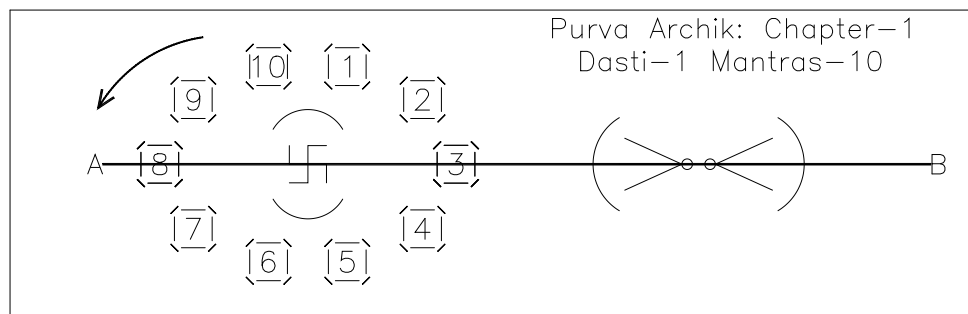

xv. The first chapter of Purva Archik is scripture of twelve Dastis. The first Dasti of the first chapter is a scripture of 10 Mantras. The block of 10 Mantras, as stands composed as Mantra of first Dasti of first chapter, is the set of ten

fourth dimensional domains which are revolving around the fifth dimensional domain.

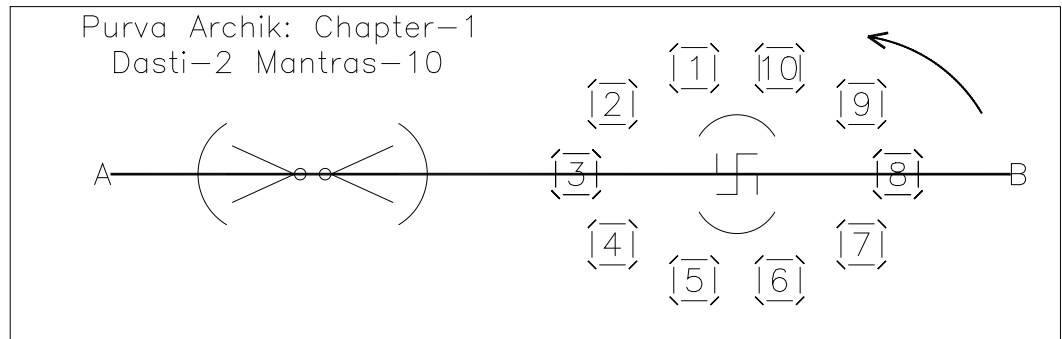

xvi. The fifth dimensional domain itself revolves around the sixth dimensional domain. The processing model of revolution of fifth dimensional domain around the sixth dimensional domain being accepted by the Samaveda is as is being shown in Vedic geometrical figure no. 1. The figure indicates a fifth dimensional domain on'the left side of the sixth dimensional domain. This is tine position at which the fifth dimensional domain starts a revolution around the sixth dimensional domain. It is this placement which becomes the basis of the set of Mantras being composed as first Dasti of the first chapter of the Purva Archik of the Samaveda.

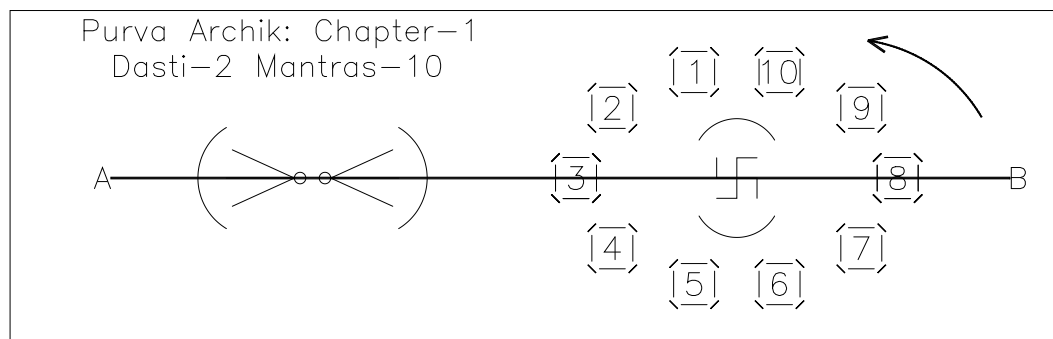

xvii. As fifth dimensional domain revolves around the sixth dimensional domain, so the next position for processing being accepted by the Samveda is the position of the fifth dimensional domain on the opposite side of the Sun. The Vedic geometrical figure no. 2 indicates the position of the fifth dimensional domain which stands acquired by it

while revolving around the sixth dimensional domain. The fifth dimensional domain being the domain around which as well are revolving ten fourth dimensional domains as such for this position value of the fifth dimensional domain as well a block of ten Mantras stands composed as Mantras of second Dasti of first chapter of the Purva Archik of the Samaveda.

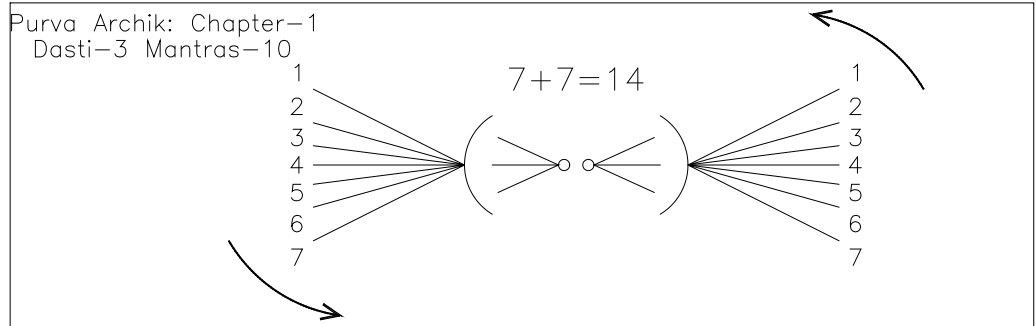

xviii. This revolution of the fifth dimensional domain around the six dimensional domain is there because of the seven streams or the Tejas flow emanating from core of the Sun on its either side. It is this flow of seven streams on the either side of the Sun, as is being indicated in Vedic geometrical figure no. 3, becomes the basis of composition of 14 Mantras of Dasti No. 3 of chapter no. 1 of Purva Archik of Samaveda.

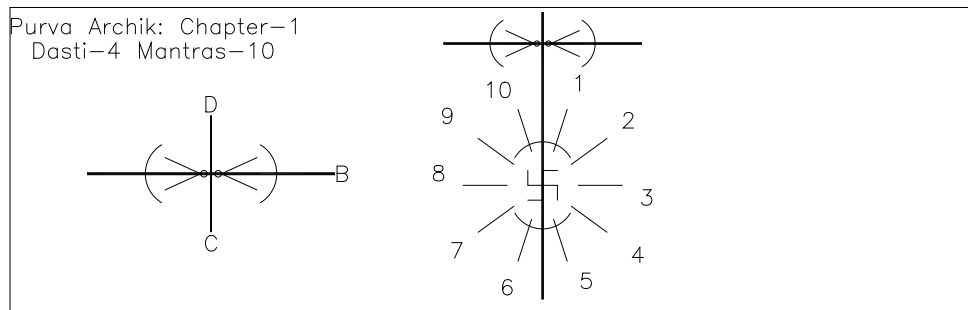

xix. The position, as is emerging, upto this stage would indicate that the processing is complete with respect to the eastern and western directions. Similarly, the fifth dimensional domain while revolving around the sixth dimensional domain would be acquiring position towards

north and south as well. The fourth Dasti of first chapter of Purva Archik is a scripture of 10 Mantras. The basis for the composition of these 10 Mantras of fourth Dasti of the first chapter are the ten fourth dimensional domains which are revolving around the fifth dimensional domain which finds placement at the northern position as is being indicated in the Vedic geometrical figure no. 4 above.

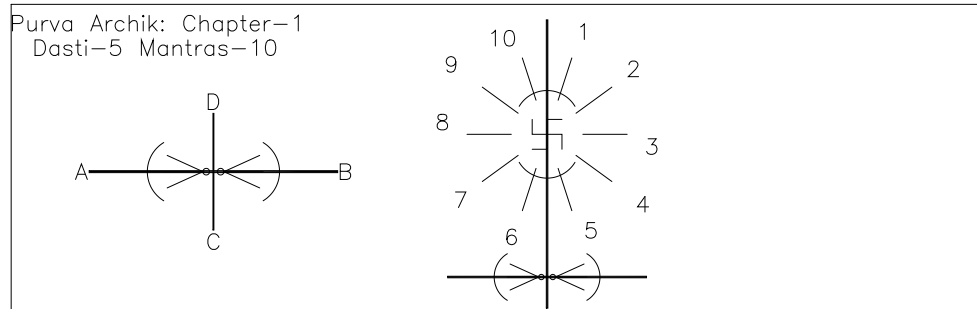

- xx. The 10 Mantras scripture of fifth Dasti of the first chapter of Purva Archik of Samaveda is having basis of ten fourth dimensional domains which are revolving around the fifth dimensional domain finding placement on the southern side of the Sun, as is being indicated in Vedic geometrical figure no. 5 above.

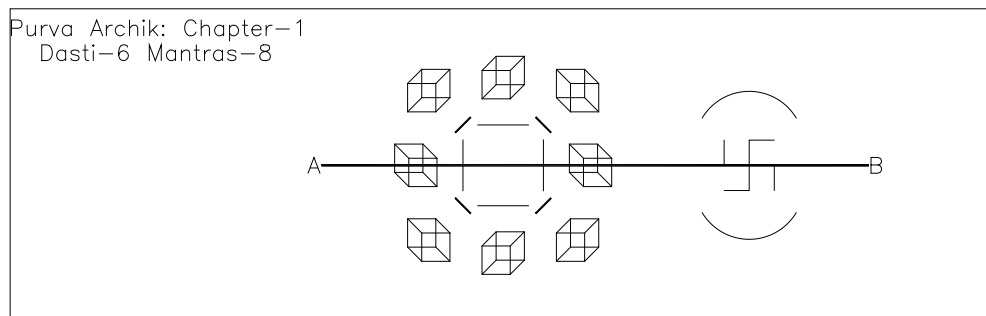

- xxi. With this the processing reaches a stage whereby the revolution stands . dimensional domain around the Sun on its all the four sides .Here it may be relevant to note that six dimensional domain is he domain whose domain part is a6 and whose frame part is constituted by The dimensional frame of The dimensional frame of the sixth dimensional domain is constituted by the fourth

dimensional domains. It is this constitution of the dimensional frame of the sixth dimensional domain which is responsible for having revolution of the fifth dimensional domain on its all four sides. It is because of it that the Samaveda processing model Purva Archik is taking into account four placements for the fifth dimensional domain while processing the revolution of the fifth dimensional domain around the sixth dimensional domain.

- xxii. With this the processing reaches a stage for taking up the constitution of the fourth dimensional domain itself. The fourth dimensional domain is the domain which is framed by 8 cubes. These 8 cubes become basis of block of 8 Mantras, which stand composed as Mantras of Dasti no. 6 of the first chapter of Purva Archik.

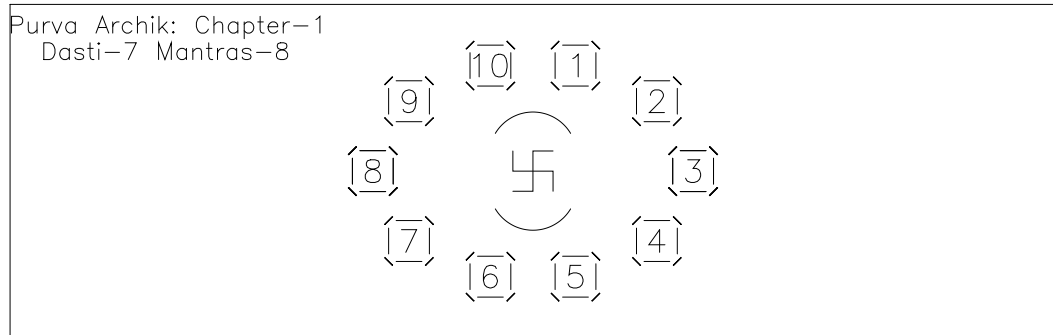

- xxiii. The fourth dimensional domain is the domain which is revolving around the fifth dimensional domain. As many as 10 fourth dimensional domains are revolving around the fifth dimensional domain. These 10 fourth dimensional domains become the basis of the scripture as stands composed as 7th Dasti of the first chapter of the Purva archik.

CHAPTER-1: DASTI – 8

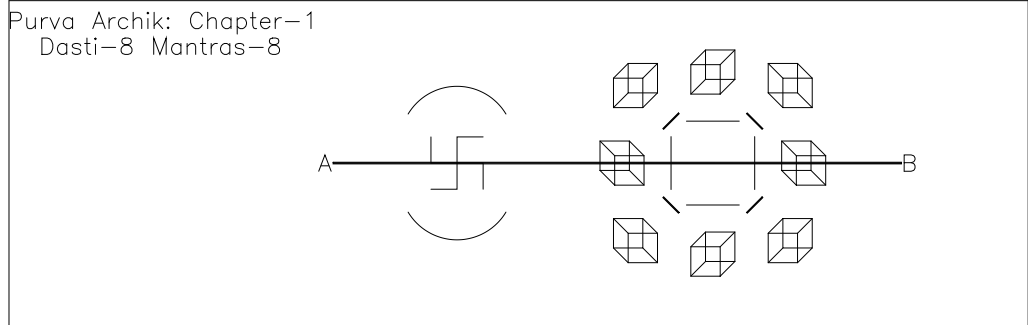

xxiv. The processing model as emerges upto this stage comes to be that fourth dimensional domain which is revolving around the fifth dimensional domain while revolving reaches the other side of the fifth dimensional domain. For the placement of the fourth dimensional domain on the other side of the fifth dimensional domain like its placement on the first side would be providing basis for composition of 8 Mantras of 8th Dasti of the first chapter of Purva Archik of the Samaveda.

CHAPTER-1: DASTI - 9

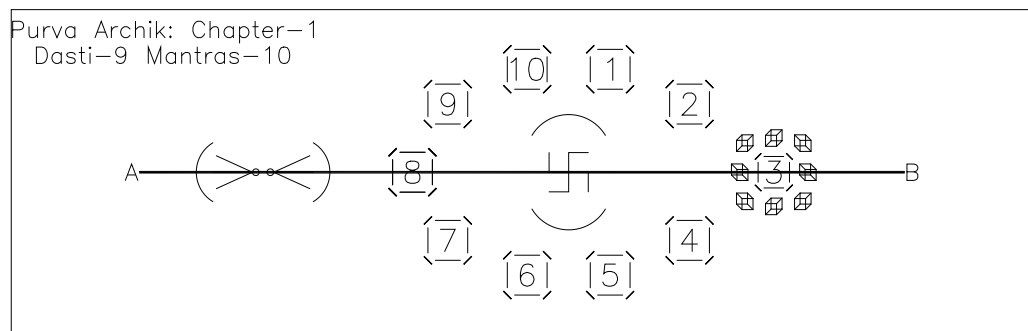

xxv. The Dastis 6th, 7th & 8th as such complete the processing in terms of the fourth dimensional domain revolving around the fifth dimensional domain. With this the processing reaches a stage where shift can be had from the fourth dimensional domain to the fifth dimensional domain. This is the reason why the 9th Dasti of the first chapter as well is a scripture of 10 Mantras.

xxvi. The processing from this stage onward becomes the processing of the fifth dimensional domain revolving around the sixth dimensional domain. Around the 5th dimensional domain are revolving ten fourth dimensional domain.

CHAPTER-1: DASTI – 10

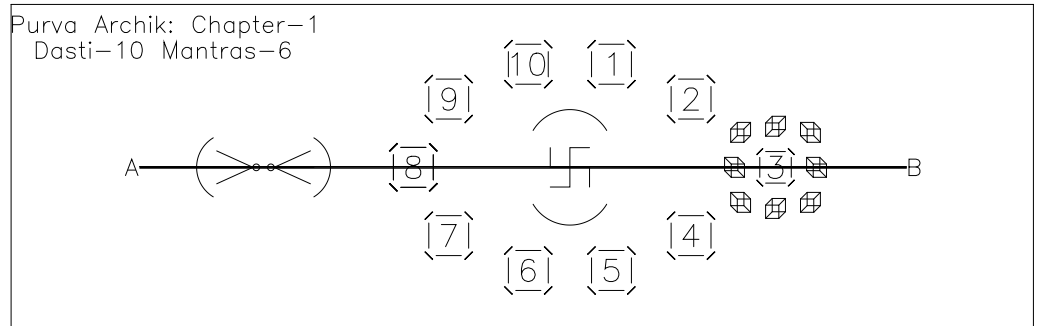

xxvii. As such, the 10th Dasti of the first chapter of the Purva Archik of Samaveda emerges to be a scripture of six Mantras. The six dimensional domain around which the fifth dimensional domain is revolving becomes the basis of the scripture of six Mantras as stands composed as tenth Dasti of the first chapter of Purva Archik of the Samaveda.

CHAPTER-1: DASTI – 11

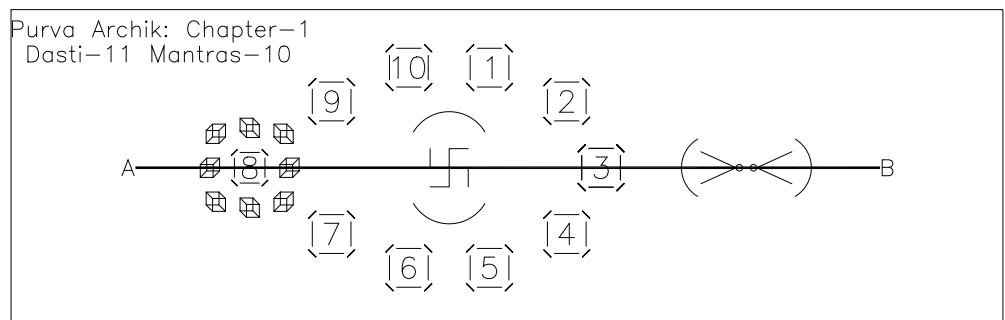

xxviii. 11th Dasti is a senpture of 10 Mantras, as the 5-space is revolving around the '6-space finds placement on the other side of the six dimensional domain. The 5-space

being the domain around which are revolving ten-4-spaces, as such, the 11th Dasti as well is a senpture of 10 Mantras. The 4- space being the domain around which are revolving eight 3-spaces, so the 12th Dasti composes 8 Mantras.

CHAPTER-1: DASTI – 12

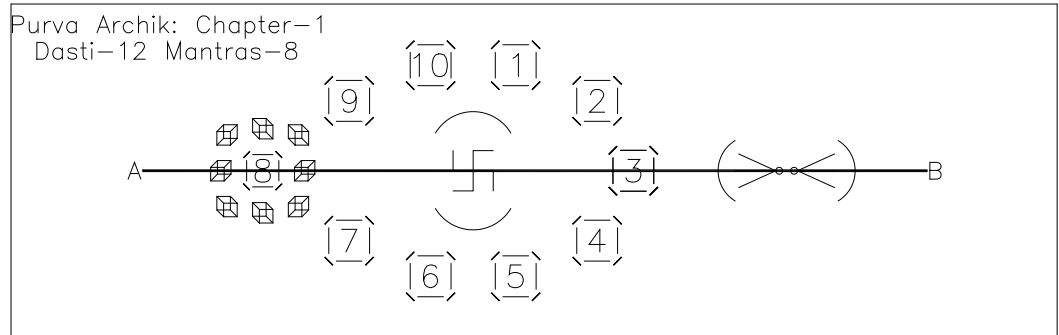

xxix. The above settlement of the Mantras of 12 Dastis of the first chapter when viewed collectively gives us a definite processing model. It emerge like this: The Sama is flowing from core of the Sun. Sun admits six dimensional domain. Around Sun are revolving 12 fifth dimensional domains. These 12 fifth dimensional domains which are revolving around the Sun becomes the basis of division of the scripture of this chapter as 12 Dastis.

xxx. Now, the Sam flow being had from core of the Sun which admits sixth dimensional domain so the processing model being worked out is in terms of the sixth dimensional frame. The sixth dimensional frame is constituted by fourth dimensional domains. The constituents of the sixth dimensional domain being the fourth dimensional domain, the compositions are being had as Mantras.

Chase Step – 84
ATHARAVVED

1. Atharavved is the fourth Ved.
2. Atharavved has nine branches.
3. With it artifices 4 and 9 get associated with this organization.
4. As such, 4-space and 9 geometries range of 4-space lead to features of organization format of Atharavved knowledge.
5. Sathapatya ved is the Upved of Atharavved.
6. Sathapatya Ved measuring rod is the basic organization format in terms of which artifices of numbers and dimensional frames get coordinated for the chase of the knowledge and organization of knowledge within frames and beyond frames of affine states which manifest as frames for the existence phenomenon within frames, prominent amongst them being the human frame, as well as existence of Earth to Sun range with pole star as the source reservoir origin
7. Sathapatya measuring rod is a synthetic set up of sequential features of hyper cube 1 to hyper cube 6 formats.

0	1	2	3	4	5	6
●	—	□	⊠	⊞	⌘	(→←)
Point	Interval	Square	Cube	Hyper cubes 4, 5, 6		

8. Three sequential ranges of features of this measuring rod are as under :

	1	2	3	4	5	6
Hyper cube	—	□	⊠	⊞	⌘	(→←)
Domain	A ¹	A ²	A ³	A ⁴	A ⁵	A ⁶

Units Artifices	1	2	3	4	5	6
Boundary Components artifices	$2b^0$	$4b^1$	$6b^2$	$8b^3$	$10b^4$	$12b^5$
Geometries / Hyper cube Version / artifices	3	5	7	9	11	13

9. Fourth range of Sequential feature of hyper cube 1 to 6 would be as per the different roles of spaces 1 to 6. These roles as origin fold, domain fold, boundary fold and dimension fold would get coordinated along 4 x 4 format and are of expression features as under:

Different roles expression of 1-space along 4 x 4 format

-2	-1	0	1	Summation value -2
-1	0	1	2	Summation value 2
0	1	2	3	Summation value 6
1	2	3	4	Summation value 10
				Total Summation value $16 = 1 \times 16$

Different roles expression of 2-space along 4 x 4 format

-1	0	1	2	Summation value 2
0	1	2	3	Summation value 6
1	2	3	4	Summation value 10
2	3	4	5	Summation value 14
				Total Summation value $32 = 2 \times 16$

Different roles expression of 3-space along 4 x 4 format

0	1	2	3	Summation value 6
1	2	3	4	Summation value 10
2	3	4	5	Summation value 14
3	4	5	6	Summation value 18
				Total Summation value $48 = 3 \times 16$

Different roles expression of 4-space along 4 x 4 format

1	2	3	4	Summation value 10
2	3	4	5	Summation value 14
3	4	5	6	Summation value 18
4	5	6	7	Summation value 22
				Total Summation value 64 = 4 x 16

Different roles expression of 5-space along 4 x 4 format

2	3	4	5	Summation value 14
3	4	5	6	Summation value 18
4	5	6	7	Summation value 22
5	6	7	8	Summation value 26
				Total Summation value 80 = 5 x 16

Different roles expression of 6-space along 4 x 4 format

3	4	5	6	Summation value 18
4	5	6	7	Summation value 22
5	6	7	8	Summation value 26
6	7	8	9	Summation value 30
				Total Summation value 96 = 6 x 16

10. Fifth row for dimensional content is as base of the origin which makes it fifth fold for the manifestation layer along which transcendence of domain fold takes place and five fold range becomes the transcendental range.

11. Distinct role of each dimensional space get coordinated along 5 x 5 formats and space wise expression for spaces 1 to 6 comes to be as under :

Different roles expression of 1-space along 5 x 5 format

-3	-2	-1	0	1	Summation value -5
----	----	----	---	---	--------------------

-2	-1	0	1	2	Summation value 0
-1	0	1	2	3	Summation value 5
0	1	2	3	4	Summation value 10
1	2	3	4	5	Summation value 15

Total Summation value $25 = 1 \times 25$

Different roles expression of 2-space along 5 x 5 format

-2	-1	0	1	2	Summation value 0
-1	0	1	2	3	Summation value 5
0	1	2	3	4	Summation value 10
1	2	3	4	5	Summation value 15
2	3	4	5	6	Summation value 20

Total Summation value $50 = 2 \times 25$

Different roles expression of 3-space along 5 x 5 format

-1	0	1	2	3	Summation value 5
0	1	2	3	4	Summation value 10
1	2	3	4	5	Summation value 15
2	3	4	5	6	Summation value 20
3	4	5	6	7	Summation value 25

Total Summation value $75 = 3 \times 25$

Different roles expression of 4-space along 5 x 5 format

0	1	2	3	4	Summation value 10
1	2	3	4	5	Summation value 15
2	3	4	5	6	Summation value 20
3	4	5	6	7	Summation value 25
4	5	6	7	8	Summation value 30

Total Summation value $100 = 4 \times 25$

Different roles expression of 5-space along 5 x 5 format

1	2	3	4	5	Summation value 15
2	3	4	5	6	Summation value 20
3	4	5	6	7	Summation value 25
4	5	6	7	8	Summation value 30
5	6	7	8	9	Summation value 35
					Total Summation value 125 = 5 x 25

Different roles expression of 6-space along 5 x 5 format

2	3	4	5	6	Summation value 20
3	4	5	6	7	Summation value 25
4	5	6	7	8	Summation value 30
5	6	7	8	9	Summation value 35
6	7	8	9	10	Summation value 40
					Total Summation value 150 = 6 x 25

12. Sathapatya measuring rod is of the features that Lord Vishnu, six head lord is the presiding deity of the measuring rod and Lord Brahma, four head lord is the presiding deity of the measure of this measuring rod.
13. It is this feature of the measuring rod as that 6-space lord is Lord of the measuring rod and 4-space lord is the Lord of the measure of the measuring rod is being the basic working rule of Vedic systems.
14. Sequentially this feature that way coordinates n-space (n-2) space as domain fold and dimension fold of respective hyper cube n. It is this domain – dimension features coordination which further leads us to the another features of manifestations, viz.

Domain fold	1- space	2- space	3- space	4- space	5- space	6- space
Dimension fold	-1 space	0- space	1- space	2- space	3- space	4- space
Super imposition value	+ 1 - 1 <hr/> 0	2 0 <hr/> 2	3 1 <hr/> 4	4 2 <hr/> 6	5 3 <hr/> 8	6 4 <hr/> 10

The above super imposition value / summation value of domain fold and dimension fold constitutes a range (0, 2, 4, 6, 8, 10) which is parallel to the boundary components hyper cubes (1, 2, 3, 4 and 5) respectively. This feature deserves to be comprehended and imbibe to have an insight about the way values of different folds, here of domain fold and dimension fold are coordinated with the boundary fold of previous hyper cube.

15. It as such would help us comprehend and imbibe the features like, as that ten boundary components of hyper cube 5 are of artifice value split parallel to domain fold and dimension fold values of hyper cube 6.
16. Further it also would help comprehend and imbibe the features of super imposition of dimension folds and domain folds.
17. Still further it also would help us comprehend and imbibe as to how ten boundary components of hyper cube 5 shall be structuring domain fold and dimension fold of hyper cube 6
18. Here it would be relevant to note that transcendental code values of formulations TVC (ष्ट) = 12 and TVC (चक्र) = 6 which will help us comprehend and imbibe as that hyper cube 6 accepts 12 boundary components. Further it also would help us comprehend and imbibe to have an insight about the external characteristics of 6 eternal circuits of human frame being

enlisted by the Vedic systems as (2, 4, 6, 8, 10, 12) which is parallel to the range of boundary components of hyper cubes 1, 2, 3, 4, 5, 6.

19. This feature as that hyper cube 6 accepts 12 boundary components and that artifice 12 accepts organization as $12 = 7 + 5$ and that artifices pair (7, 5) is parallel to 7-space as domain fold and 5-space as dimension fold of hyper cube 7. Further as that this feature permits extension for whole range of hyper cubes and in general $2n$ boundary components as $2n = (n + 1) + (n-1)$.
20. Still further the feature of artifices as that $4n = (2n+1) + (2n - 1)$ which further permits re-organization as $4n = (2n+1) + (2(n-1) + 1)$, which is parallel to $2n + 1$ geometries range of n -space / $(2n + 1)$ versions of hyper cube n and $2(2n-1) + 1$ being parallel to geometries range of hyper cube $(2n - 1)$ space / version of hyper cube $(n-1)$, as such the double of boundary components of hyper cube n shall be equal to the summation values of geometries of hyper cube $n-1$ together with geometries range of hyper cube n .
21. These two features (i) super imposition of domain fold and dimension fold, and (ii) doubling of the boundary of hyper cube when taken together shall be helping us work out the gaps between pair of hyper cubes.
22. It is this feature of structuring the gaps between consecutive hyper cubes in terms of artifices of numbers and dimensional frames in the form of features of different folds of manifestation layers helps attain continuum for the chase.
23. Atharavved samhita accept organization as 20 Kandas. Artifice 20 and formulation 'कांडः' deserve to be chased for comprehension and imbibing of the organization feature of Atharavved and for attaining insight about this organization.

24. Formulation (कांडः) when chased in terms of its transcendental code values (i.e) TVC (कांडः) = $1 + 2 + 7 + 5 + 1 + 13 = 29 = 16 + 13 = (5 + 6 + 5) + (4+5+4)$.
25. Here it would be relevant to note that this organization of artifice 29 is parallel to the organization of Ganita Sutras (sixteen sutras and thirteen upsutras).
26. Further this organization is parallel to the 29 archiks range of Sama veda.
27. Still further it is parallel to 29 shalokas range of 5th chapter of Shrimad Bhagwad Geeta.
28. Still further this is parallel to 29 shalokas range of 13th chapter of Shrimad Durga Saptasati.
29. Further as that organization of artifice $29 = (5+6+5) + (4+5+4)$. It is a six steps long sequential organization for transcendental domain (5-space as domain) with self referral origin (6-space as origin) along with sequential organization for the creative boundary of transcendental domain (4-space as boundary of 5-space) and 5-space simultaneously being in the role of origin of 4-space.
30. The artifice 20 is of values and features parallel to 20 as transcendental code values for summation of quadruple dimensions of equal value of any order as that $20 = n + (n + 2) + 6 - (12 - 2n)$, for all values of n.
31. Still further it also would be relevant to note that the sequential range of synthesis values of 8 dimensions of whole range of dimensional orders comes to be :

Synthesis values of eight dimensions

Dimensional order	Synthesis values of eight dimensions
-8-space as dimension	216
-7-space as dimension	196
-6 space as dimension	176
-5-space as dimension	156
-4-space as dimension	136
-3-space as dimension	116
-2-space as dimension	96
-1-space as dimension	76
0-space as dimension	56
1-space as dimension	36
2-space as dimension	16
3-space as dimension	-4
4-space as dimension	-24
5-space as dimension	-44
6-space as dimension	-64
7-space as dimension	-84
8-space as dimension	-104

116, 96, 76, 56, 36, 16, -4, -24, -44, -64, -84, -104, ---

The above sequence accepts difference value for pair of sequential steps being '20' and that the sequential value for zero dimensional order '0-space' dimensional order is of synthesis value of eight dimensions of 0 value.

32. The organization of $56 = 8 \times 7$ is the feature, whose chase would add to comprehension of this feature.
33. It would be a blissful exercise to tabulate transcendental code values of different formulations of Atharavved texts and to compile one's own dictionary.

34. One may start with TCV (अथर्ववेदः)= 50 which is a total summation value of transcendental ranges accepting organization along 5 x 5 matrix format for different roles of 2-space as under :

-2	-1	0	1	2
-1	0	1	2	3
0	1	2	3	4
1	2	3	4	5
2	3	4	5	6

35. The above five transcendental ranges are of hyper cubes 0, hyper cube 1, hyper cube 2, hyper cube 3 and hyper cube 4 with 2-space as transcendental base as origin fold, as domain fold, as boundary fold and dimension fold respectively.

*